



TAB INSERTION SYSTEMS FOR THE PRINTING AND PAPER INDUSTRY

The World Counts on Vacuumatic

For over half a century the world has been enjoying the benefits of Vacuumatic's pioneering paper counting technology.

We are global leaders in the production of state-of-the-art paper counting, batch marking and tabbing equipment.

Vacuomatic supplies the security and commercial print industries, paper mills and converters with highest quality products.

When you are working long term with the world's central banks, security and commercial printers, government departments, pharmaceutical houses and paper mills there is no room for error and certainly no room for complacency.

Our machines are designed, developed and manufactured in-house, in the UK, for distribution worldwide from our Colchester HQ, via Vacuumatic companies in the US and Germany and through our comprehensive global network of professional distributors.



What it all adds up to:

Vacuomatic exports equipment to customers in over ninety countries and is the only supplier in the world offering multiple counting technologies; pin-&-blade, rotary disc, optical and tabbing.

Vacuomatic has earned its reputation for precision and reliability; our customers know they can count on us to deliver.

www.vacuomatic.com

The future always brings fresh challenges. At Vacuumatic we enjoy the opportunity of finding viable solutions to the accuracy and security demands faced by our customers.

We have a clear focus on our R&D programme; regularly reviewing, upgrading and innovating our product inventory. Our history underlines our long term strategic commitment to progress in the field of paper counting and batching - three distinct tab insertion products, for example, constitute the widest range available from one manufacturer.

Vacuumatic has built its name around quality, accuracy, efficiency and reliability. But more than that, we back up our mission statement to supply the world with pioneering, robust and competitively priced counting technology with the added value of unrivalled after sales service and spare parts support.

Vacuumatic consider customers to be long term partners rather than simply clients. We have a dedicated team of technical experts and spare parts coordinators working alongside a comprehensive network of distributors, covering the globe.

At Vacuumatic our entire product range is produced in-house, from initial concept, design and development, to manufacturing. Not just the mechanics and hardware; we also develop our own electronic components and software solutions.

We can offer a range of customisation options, enabling us to manufacture the highest quality machinery to our customers' exact specifications. We are the only supplier that can offer both security and commercial clients a 'best practice' consultation to identify specific requirements.

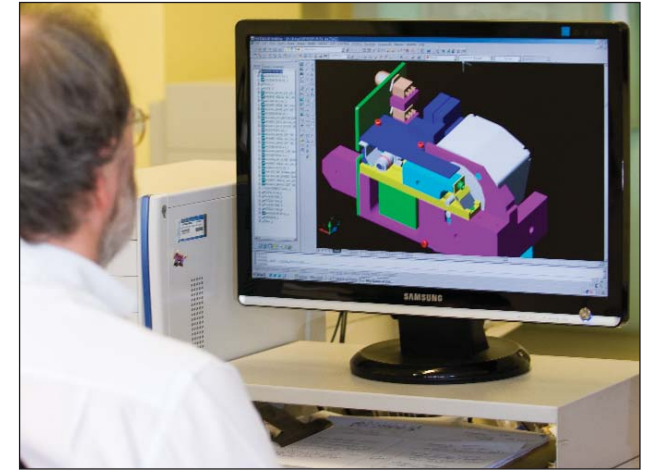

In-house Creativity, Dedicated Support and Customised Solutions

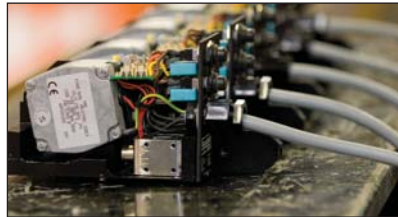

Combined Universal Tab Inserter (CUTI)

Typical Applications

Commercial printing

Trade finishing and diecutting

The Combined Universal Tab Inserter is Vacuumatic's compact tab inserter system, enabling accurate tabbing and batching of sheeted piles with the minimum requirements of space and investment cost. Usually pedestal mounted, the unit can be interfaced directly to most printing presses, or triggered via a laser sensor attachment.

The CUTI is often supplied to commercial printers looking for greater accuracy in batching their printed products. This can result in minimisation of waste sheets and improved productivity in subsequent finishing processes.

Features

- Compact and self contained
- Press interface or laser sensor trigger
- Supplied complete with pedestal stand
- Provides accurate batch tabbing and total sheet count
- Choice of chute length options

Benefits

- Flexible, cost effective unit
- Easily transferred between presses
- Low maintenance
- Simple self-installation when ordered with laser sensor

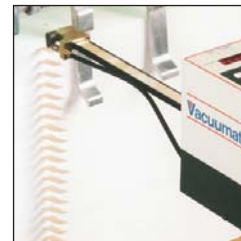

*CUTI with 600mm chute
on 1m pedestal*



VUTI with 450mm chute on 1.5m pedestal

Vacuumatic Universal Tab Inserter (VUTI)

The Vacuumatic Universal Tab Inserter is the top-end solution for highly accurate online counting and batching of sheet delivered products such as sheet paper, commercial print and packaging. Mounted at the delivery end of almost any sheeter or printing press, the VUTI system enables operators to count and batch good copy, isolate areas of make-ready or spoil and return an accurate count of delivered piles.

The VUTI is supplied with either a pedestal stand or machine mounting kit. Tabs can be triggered either by signals from the press or sheeter counting system, or from one of a range of independent sensor systems that are available from Vacuumatic. Tabbing systems have been a feature of the Vacuumatic portfolio for over 30 years, the VUTI is the latest in a long line of market leading products in this field.

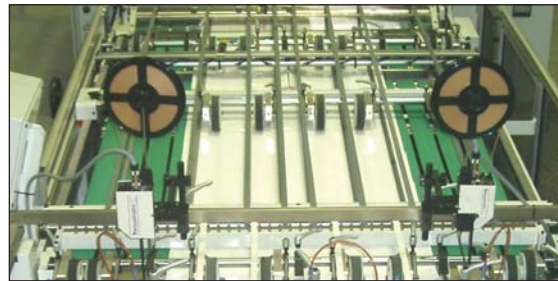

Typical Applications

Papermills using automatic sheeting systems

Industrial & commercial sheetfed printing

Sheetfed packaging and label printing

Trade finishing and die cutting

Features

- Compact unit
- Flexible mounting options
- Open chute design - easy removal of residual tape
- Automatic tape out/jam alarm
- Choice of standard chute lengths
- VUTI Plus waste management upgrade option – includes printer and ink marker system

Benefits

- Accurate on-press/sheeter counting and batching
- Prevents inaccurate deliveries – overs and unders
- Maintains count accuracy when sheets are removed
- Minimises waste paper

Fully Automated Tape Feed and Cut Sequence

SMART 1

Vacuumatic's new SMART 1 tab insertion system has been designed to offer tabbing as cost-effectively as possible on presses and sheeters that are equipped with their own programmable counting or sheet inspection system. Such machines can provide a 24v pulse signal to fire and cut the tab, meaning that there is no need for the Electronic Counter Control unit or sensors that are required to drive and control the VUTI tab insertion systems. SMART 1 is often supplied direct to press and sheeter manufacturers to be factory fitted, and sometimes as a replacement for old or worn tab insertion systems.

SMART 1 is a product for very specific applications, so please be sure to consult with Vacuumatic or your local distributor prior to placing an order.

Typical Applications

Papermills using automatic sheeting systems

Commercial printing

As part of a sheet inspection system



Rear view
of Smart 1

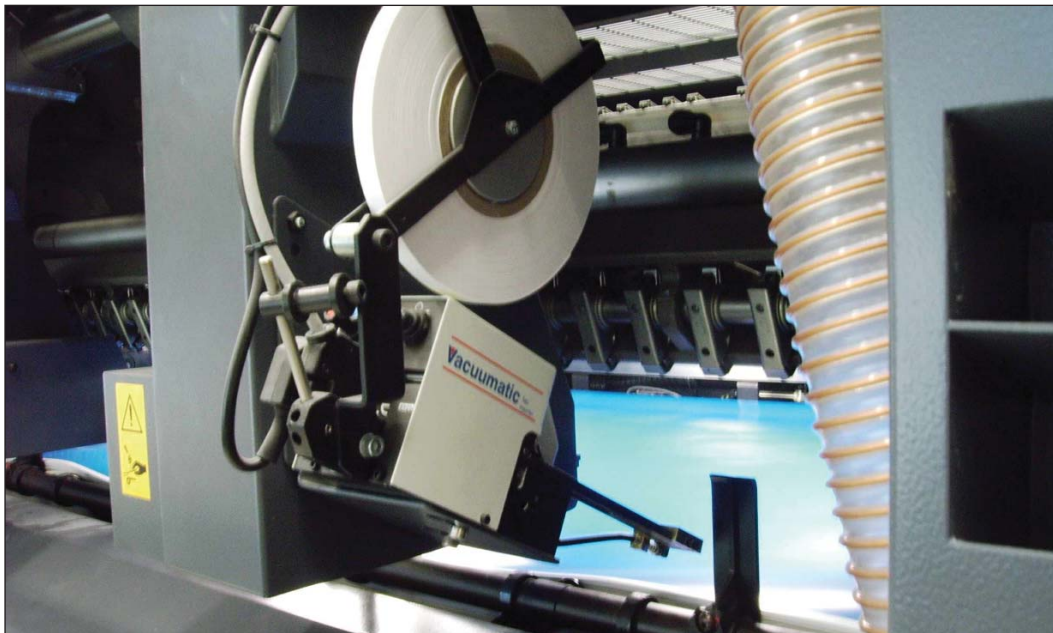

Features

- Compact unit
- Flexible mounting options
- Only requires one simple firing signal
- Adjustable cut delay
- Adjustable tape length
- Choice of standard chute lengths

Benefits

- Accurate waste or makeready sheet marking

Technical Information

Specification	VUTI	CUTI	SMART 1
Maximum count speed	120,000 sheets per hour	25,000 sheets per hour	n/a
Tab insertion	2 - 9,999 sheets	6 - 9,999 sheets	maximum 2 tabs per second
Tape cut delay	1-99 sheets	5 sheets (fixed)	0.5 - 5 seconds
Standard chute lengths*	150/300/450/600/750 mm approx. 6"/12"/18"/24"/32"	150/300/450/600 mm approx. 6"/12"/18"/24"	150/300/450/600 mm approx. 6"/12"/18"/24"
Electrical specification	230v/50Hz or 115v/60Hz	230v/50Hz or 115v/60Hz	230v/50Hz or 115v/60Hz
Airborne noise emission	up to 78dB(A)	up to 76dB(A)	up to 78dB(A)

*Special chutes available on request

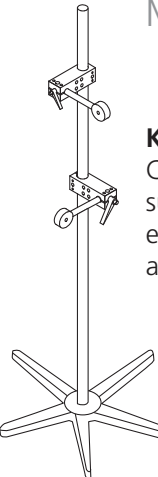

Mounting Options

Kit A: Mobile Pedestal Unit
Complete with block and arm support for tabber body and electronic controller with arm adjusters.

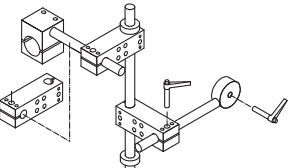

Kit C: 7-Piece Multi-Universal Mount
Comprising 'Kit B' plus two steel extended rods and two additional flat mounted brackets.

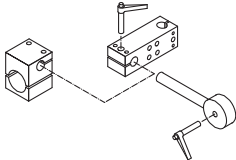

Kit B: 3-Piece Universal Mount
Comprising black anodised circular bar mounting bracket (38mm diameter) and alternative black anodised universal flat mounted bracket, both complete with screw threaded lever arm adjusters, plus steel rod support arm.

Cutting Head Options

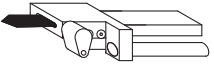

1. Straight tape firing

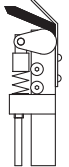

2. Tape deflecting head for firing up.

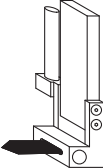

3. 90° tape deflecting head for firing down.

Vacuomatic have made every effort to ensure the accuracy of the information contained within this brochure. Vacuomatic operate a research and development programme which drives continuous product improvement. The services and product specifications contained within this brochure may change without notice.

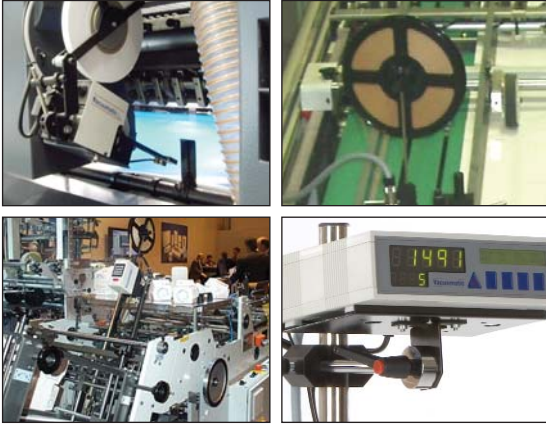

Vacuumatic Ltd.

8 Brunel Way, Colchester, Essex, CO4 9QX, United Kingdom
Tel: +44 (0)1206 841100 Fax: +44 (0)1206 841166
Email: enquiries@vacuumatic.com

Vacuumatic Maschinen GmbH.

Am Schornacker 41a, D-46485 Wesel, Germany
Tel: +49 (0)281 33995 0 Fax: +49 (0)281 33995 20
Email: info@vacuumatic.de

Vacuumatic Paper Counting Machines, Inc.

150 Engineers Drive, Hicksville, NY 11801, USA
Tel: 1 800 683 6619 Fax: 1 516 822 8766
Email: info@vacuumaticinc.com

www.vacuumatic.com



Certificate No. FM 14585
BS EN ISO 9001

